



GUARDING YOUR VALUES



www.gjerde.com

JOHN JERDE

guarding your values – when safety counts!

At the end of the day nothing is more important than the health and lives of the people working on board. Accidents sometimes happens and at sea and help can be far away. In those situations, tank vent check valves have one job: to guard the ship from taking in water, thus stabilizing the situation until the crew and finally the ship, can be brought safely ashore.

John jerde is located on the west coast of Norway, in the heart of an innovative world leading maritime cluster, close to ship owners, designers, seafarers, and machinists.

The company has 45 years of experience in the market of air vent check Valves and is certified ISO 9001 – 14001 - 45001.

The HIDE-series is our new generation -valve and the most reliable valve in the market. Its optimized design is the result of an extensive testing and development work focusing on all critical safety aspects.

That's why you should choose the -valves!

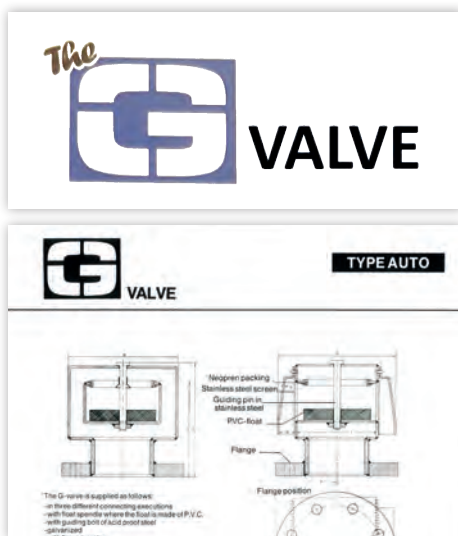

CONTENTS

03	HIDE-family
11	AERO-family
18	 -STRAINERS
24	Other options

THE ADVANTAGES

of -valves

1. The guiding pin, which ensures perfect performance even under tilted conditions.

The unique disc-float shaped for optimal airflow with integrated lip seal gaskets

- Provides protection against damage from overfilling
- Provides efficient noise suppression and “clapping” of float
- Prevents leakage in dipping situations. The disc and pin concept protects the closing mechanism and makes the -valve the most reliable valve in the market

2. The cross-section area inside the valve is larger than the air flow area required by the regulations. This decreases the risk of “suction blocking” and structural breakdown.

3. The flame screen is of robust construction and is re-enforced to prevent breakdown due to water overfill, or debris in water. The screen is large, which minimizes pressure drop.

Options

- ▶ Flame/Bug/Rat screen
- ▶ Heating/Winterization
- ▶ Additional mud chamber preventing mud from entering the valve (see page 29)
- ▶ Painting
- ▶ Mounting alternatives: flanged, threaded or weldment

4. The shield protects the closing mechanism from airborne pollutants such as dirt and spray painting.

The heating solution for winterization (optional)

- Ensures proper functioning in icing conditions down to -50°C
- Is simple, robust and reliable

5. IECEx approved
6. Can be ordered in corrosion resistant aluminum, galvanized steel, stainless steel or higher Duplex steel qualities.
7. Fulfils the important requirements of DNV-GL Ship Rules Pt.3 Ch.3 Sec.6 Openings and closing appliances: I 308, 401, 402, 403 og 404
8. Approved by all major classification societies:



HIDE float

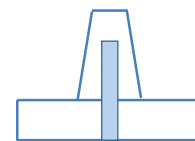

AERO float

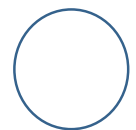

Conventional float

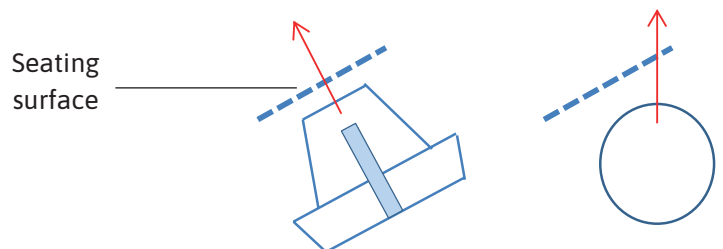

Direction of buoyant float against seating surface in tilted configuration

PRODUCT RANGE

Tank vent check valves

Product range	Casted Aluminum	Welded Aluminum	Welded Steel *
HIDE	DN40 - DN300	DN 200 - DN 600	All dimensions
AERO		DN 40 - DN 600	All dimensions

* Galvanized steel, stainless steel or higher Duplex steel qualities.

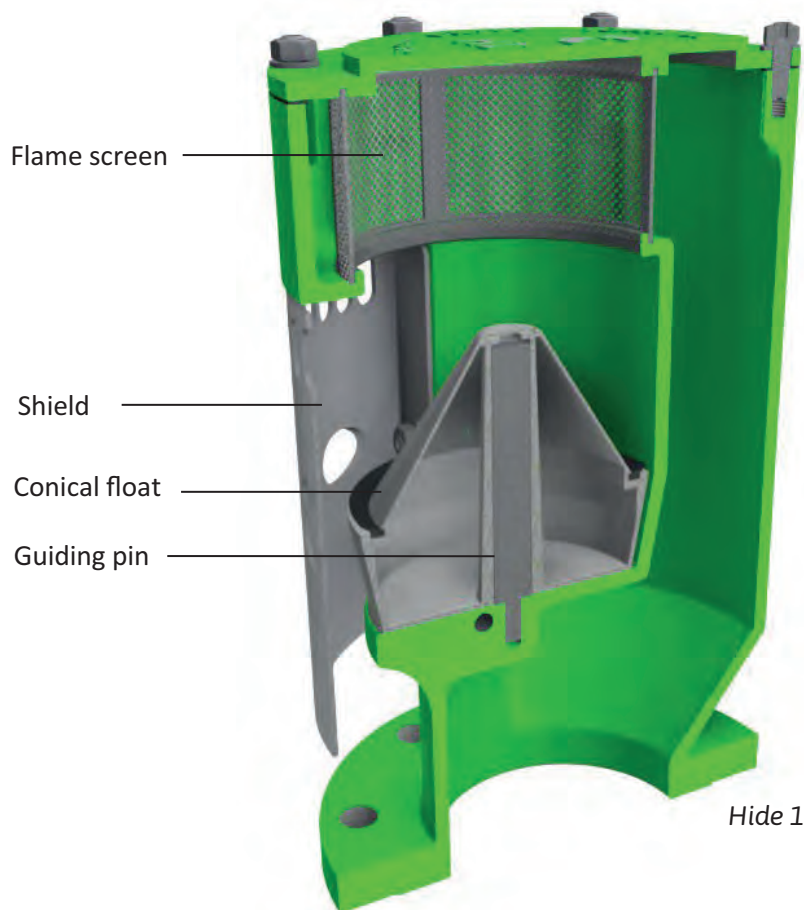

THE HIDE SERIES

The new generation -valves

The most common failures due to malfunction of tank vent check valves are related to either water ingress or abnormal pressure in tank.

Water ingress typically occurs when the ship is listing heavily and the valves are completely or partially submerged. If the float is stuck, damaged or missing, the tank will take in water through the vent valve. Such a situation can rapidly become serious, especially if no pump can be activated due to electrical failure or missing machinist on board.

Abnormal tank pressure is a result of blocked or choked air flow through the vent valve. Both over and underpressure caused by a stuck float can create significant stress levels in tanks or hull structure. In worse case, this could lead to structural breakdown due to suction blocking or overfilling of tank. Correct dimensioning of tank venting is therefore essential to avoid abnormal pressures.

The reliability of the valves is of the highest importance for safety at sea. John Gjerde AS believes in continuous innovation and our mission is to improve the safety of the crew, their vessels and the environment. We have solid in-house competence and can rely on own test facilities to study all safety aspects related to our products.



HIDE 1 ALUMINUM

on deck

The most commonly used air vent head for ships. The HIDE 1 Aluminum is a die-cast valve made for installation outside on-deck. Used to ventilate all tanks on board for cargo, ballast water, wastewater, fresh water, lubricating oil, fuel oil, etc. Prevents water from entering the tanks.

HIDE valves are approved by all the most common classification societies. For pressure drop and flow rate, visit our web page www.gjerde.com

Options:

- ▶ Flame/Bug/Rat screen
- ▶ Heating/Winterization
- ▶ Additional mud chamber preventing mud from entering the valve (see page 29)
- ▶ Painting
- ▶ Mounting alternatives: flanged or threaded

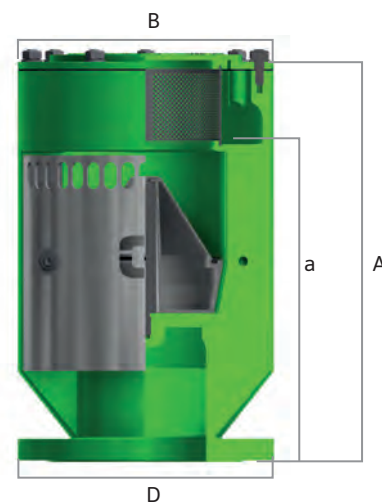

Performance, weight and size

Hide 1 Aluminium	DN – Inch									
	40 - 1 1/2"	50 - 2"	65 - 2 1/2"	80 - 3"	100 - 4"	125 - 5"	150 - 6"	200 - 8"	250 - 10"	300 - 12"
A (mm)	175	228	250	274	316	386	460	533	680	800
B (mm)	120	140	160	200	220	250	285	343	406	460
a (mm)	131	180	190	212	239	292	358	400	510	585
D	Flange connection acc. to any standard.									
Weight (kg)	2	3	3,5	4	6	11	18	30	44	77
Heating (Watt)	75	75	75	75	75	120	120	180	180	180
Inlet air flow in m³/h¹⁾	120	160	240	470	595	1060	1400	2375	3890	5600
Inlet air flow in m³/h²⁾	125	185	240	540	595	1100	1400	2600	3710	5600

1) No screen 2) With screen

HIDE 1 STEEL

on deck

The most commonly used air vent head for ships. The HIDE 1 Steel is a welded valve for demanding conditions made for installation outside on-deck. Used to ventilate all tanks on board for cargo, ballast water, wastewater, fresh water, lubricating oil, fuel oil, etc. Prevents water from entering the tanks. HIDE valves are approved by all the most common classification societies. For pressure drop and flow rate, visit our web page www.gjerde.com

Options:

- ▶ Flame/Bug/Rat screen
- ▶ Heating/Winterization
- ▶ Additional mud chamber preventing mud from entering the valve (see page 29)
- ▶ Painting
- ▶ Mounting alternatives: flanged, threaded or weldment
- ▶ Can be ordered in galvanized steel, stainless steel or higher Duplex steel qualities

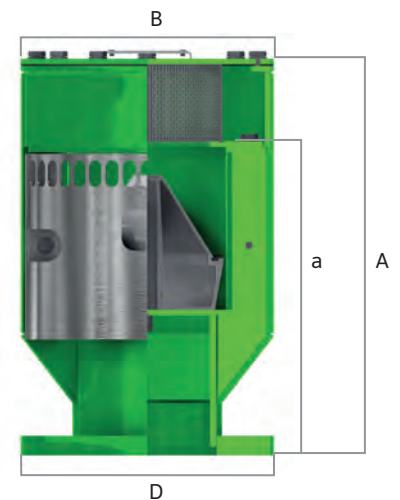

Performance, weight and size

Hide 1 Steel	DN - Inch														
	40 - 1 1/2"	50 - 2"	65 - 2 1/2"	80 - 3"	100 - 4"	125 - 5"	150 - 6"	200 - 8"	250 - 10"	300 - 12"	350 - 14"	400 - 16"	450 - 18"	500 - 20"	600 - 24"
A (mm)	248	260	283	303	356	420	454	520	722	823	937	1003	1145	1437	1601
B (mm)	140	140	169	194	220	250	285	340	430	520	620	650	820	920	1020
a (mm)	195	195	200	222	258	308	335	372	546	607	704	745	857	1070	1170
D	Flange connection acc. to any standard.														
Weight (kg)	9	9,3	12	14,5	19,4	26,2	34,3	48	79	113	148	161	230	310	442
Heating (Watt)	75	75	75	75	75	120	120	180	180	180	2x180	2x180	2x180	2x180	2x180
Inlet air flow in m³/h¹⁾	120	160	240	470	595	1060	1400	2375	3890	5600	10045	14930	16600	18380	33590
Inlet air flow in m³/h²⁾	125	185	240	540	595	1105	1400	2600	3710	5600	10045	14930	16600	18380	33590

1) No screen 2) With screen

HIDE 2 STEEL

through super structures

The HIDE 2 is a welded steel made for ventilation through superstructures. Commonly used in demanding conditions and cases with longer distances to open deck, such as passenger vessels and accommodation areas.

HIDE valves are approved by all the most common classification societies. For pressure drop and flow rate, visit our web page www.gjerde.com



Options:

- ▶ Flame/Bug/Rat screen
- ▶ Heating/Winterization
- ▶ Additional mud chamber preventing mud from entering the valve (see page 29)
- ▶ Painting
- ▶ Mounting alternatives: flanged, threaded or weldment
- ▶ Can be ordered in galvanized steel, stainless steel or higher Duplex steel qualities

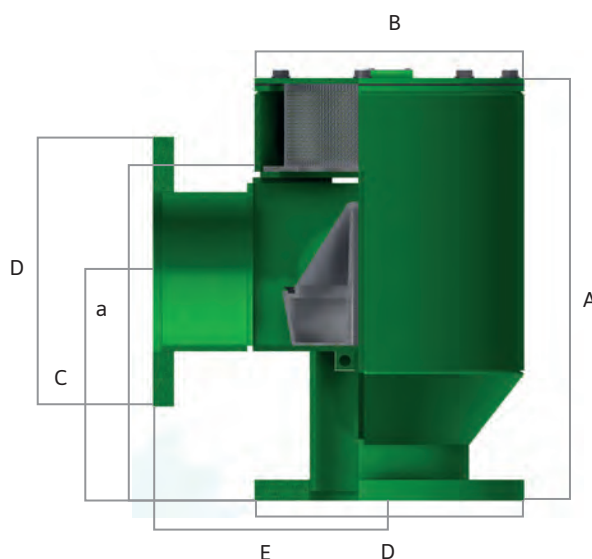

Performance, weight and size

Hide 2 Steel	DN - Inch														
	40 - 1 1/2"	50 - 2 2"	65 - 2 1/2"	80 - 3 3"	100 - 4 4"	125 - 5 5"	150 - 6 6"	200 - 8 8"	250 - 10 10"	300 - 12 12"	350 - 14 14"	400 - 16 16"	450 - 18 18"	500 - 20 20"	600 - 24 24"
A (mm)	248	260	283	303	356	420	454	520	722	823	937	999	1144	1434	1586
B (mm)	140	140	169	194	220	250	285	340	430	520	620	650	820	920	1020
C (mm)	130	130	150	180	200	220	250	260	350	420	474	523	547	712	768
E (mm)	110	116	144	162	202	225	242	300	383	440	470	520	560	782	854
a (mm)	195	195	200	222	258	308	335	372	546	607	710	745	848	1070	1170
D	Flange connection acc. to any standard.														
Weight (kg)	11	13	17	22	26	35	47	63	97	133	180	180	297	409	562
Heating (Watt)	75	75	75	75	75	120	120	180	180	180	2x180	2x180	2x180	2x180	2x180
Inlet air flow in m³/h¹	77	106	143	235	283	530	955	1585	3005	3815	4155	5880	8590	11310	14250
Inlet air flow in m³/h²	77	113	143	235	283	575	1020	1245	3005	3815	5195	5880	8590	11310	15270

1) No screen 2) With screen

HIDE 2 ALUMINUM

through super structures

The HIDE 2 Aluminum is a die-cast valve made for ventilation through superstructures. Commonly used in demanding conditions and cases with longer distances to open deck, such as passenger vessels and accommodation areas.

HIDE valves are approved by all the most common classification societies. For pressure drop and flow rate, visit our web page www.gjerde.com

Options:

- ▶ Flame/Bug/Rat screen
- ▶ Heating/Winterization
- ▶ Additional mud chamber preventing mud from entering the valve (see page 29)
- ▶ Painting
- ▶ Mounting alternatives: flanged or threaded

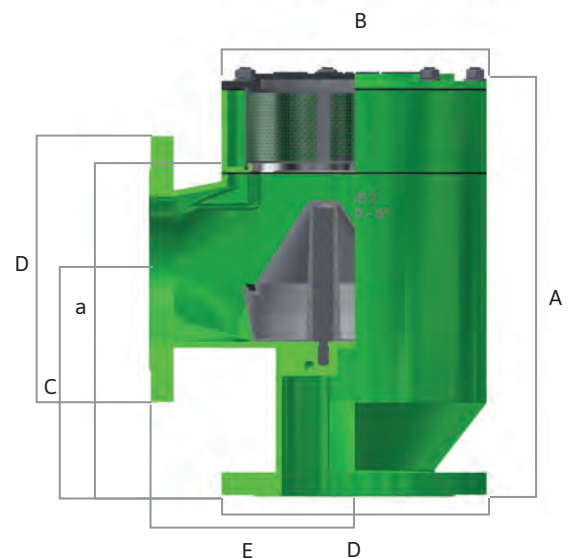

Performance, weight and size

Hide 2 Aluminum	DN – Inch								
	DN50 - 2"	DN65 - 2 1/2"	DN80 - 3"	DN100 - 4"	DN125 - 5"	DN150 - 6"	DN200 - 8"	DN250 - 10"	DN300 - 12"
A (mm)	234	277	307	354	420	454	518	728	847
B (mm)	140	160	194	210	250	285	340	430	520
C (mm)	116	144	162	202	225	242	260	383	440
E (mm)	130	150	180	200	220	250	300	350	420
a (mm)	179	208	243	270	315	354	370	550	663
D	Flange connection acc. to any standard.								
Weight (kg)	5	6	8	11	14	19	32	52	75
Heating (Watt)	75	75	75	120	120	120	180	180	180
Inlet air flow in m³/h¹⁾	106	143	235	283	530	955	1585	3005	3815
Inlet air flow in m³/h²⁾	113	143	235	283	575	1020	1245	3005	3815

1) No screen 2) With screen

HIDE 3 STEEL

with closing device

The HIDE 3 Steel is a welded valve most commonly used for dry cargo tanks. Equipped with a manual closing device to avoid any leakage into the dry cargo. HIDE 3 has determined flow characteristics and a robust lip seal gasket for optimal tightness.

HIDE valves are approved by all the most common classification societies. For pressure drop and flow rate, visit our web page www.gjerde.com

Options:

- ▶ Flame/Bug/Rat screen
- ▶ Heating/Winterization
- ▶ Additional mud chamber preventing mud from entering the valve (see page 29)
- ▶ Painting
- ▶ Mounting alternatives: flanged, threaded or weldment
- ▶ Can be ordered in galvanized steel, stainless steel or higher Duplex steel qualities.

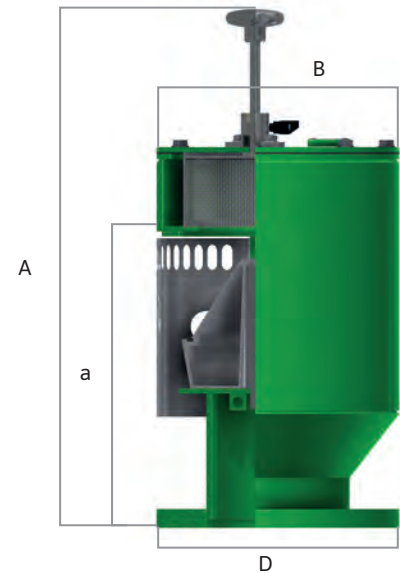

Performance, weight and size

Hide 3 Steel	DN – Inch														
	DN40 - 1 1/2"	DN50 - 2"	DN65 - 2 1/2"	DN80 - 3"	DN100 - 4"	DN125 - 5"	DN150 - 6"	DN200 - 8"	DN250 - 10"	DN300 - 12"	DN350 - 14 "	DN400 - 16"	DN450 - 18"	DN500 - 20"	DN600 - 24"
A (mm)	343	343	398	422	486	570	608	714	931	1110	1200	1265	1450	1650	1750
B (mm)	140	140	169	194	220	250	285	340	430	520	620	650	820	920	1020
a (mm)	195	195	200	222	258	308	335	372	546	607	704	745	857	1070	1170
D	Flange connection acc. to any standard.														
Weight (kg)	9	9	14	18	23	28	38	50	81	112	150	165	235	315	447
Heating (Watt)	75	75	75	75	120	120	120	180	180	180	180*2	180*2	180*2	180*2	180*2
Inlet air flow in m³/h¹⁾	122	162	240	470	595	1060	1400	2375	3890	5600	10050	14930	16600	18380	33590
Inlet air flow in m³/h²⁾	127	184	240	545	595	1105	1400	2600	3710	5600	10050	14930	16600	18380	33590

1) No screen 2) With screen

HIDE 6 STEEL

Inverted mounted

The HIDE 6 Steel is a welded vent check valve for venting through superstructures, made for inverted mounting with inlet at the top. All HIDE valves are self-draining, which prevents leakage into the tank. HIDE valves are approved by all the most common classification societies. For pressure drop and flow rate, visit our web page www.gjerde.com

Options:

- ▶ Flame/Bug/Rat screen
- ▶ Heating/Winterization
- ▶ Additional mud chamber preventing mud from entering the valve (see page 29)
- ▶ Painting
- ▶ Mounting alternatives: flanged, threaded or weldment
- ▶ Can be ordered in galvanized steel, stainless steel or higher Duplex steel qualities.

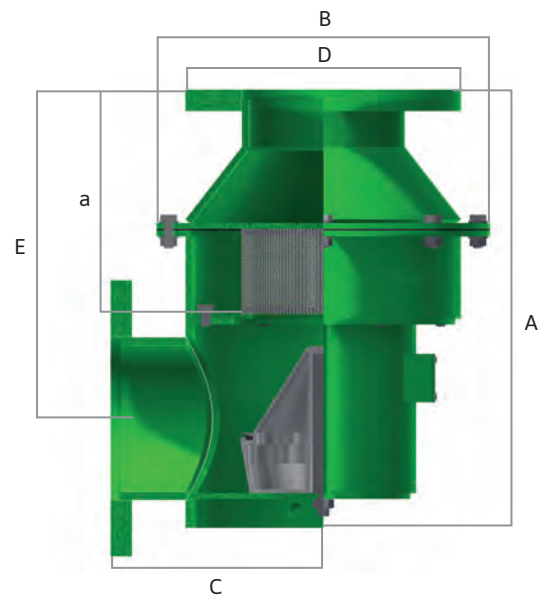

Performance, weight and size

Hide 6 Steel	DN – Inch									
	40 - 1 1/2"	50 - 2"	65 - 2 1/2"	80 - 3"	100 - 4"	125 - 5"	150 - 6"	200 - 8"	250 - 10"	300 - 12"
A (mm)	247	247	299	315	357	418	453	558	684	810
B (mm)	179	179	219	244	270	300	345	410	490	600
C (mm)	130	130	140	160	170	190	220	250	300	360
E (mm)	190	190	230	240	270	320	340	420	520	620
a (mm)	118	118	158	160	196	223	231	283	348	425
D	Flange connection acc. to any standard.									
Weight (kg)	10	12	16	20	24	34	41	61	88	123
Heating (Watt)	75	75	75	75	120	120	120	180	180	180
Inlet air flow in m ³ /h ¹⁾	240	105	109	290	370	620	1145	1700	2825	4330
Inlet air flow in m ³ /h ²⁾	210	115	200	255	370	620	1145	1700	2475	4330

1) No screen 2) With screen

HEATING / WINTERIZATION

a simple and robust solution

John Gjerde's heating element ensures fully operational functions in icing conditions down to -50°C thanks to its location directly close to the guiding pin. The heating solution is simple, robust and optimized to reduce the total power consumption by 80% compared to conventional solutions.

- ▶ Easy installation
- ▶ All casted valves are prepared for heating element and are easy to upgrade
- ▶ ATEX and IECEx approved



Technical data, typical vessel configuration with 80 off valves

	Max startup effect (W)	Oper. effect (W)	Max HIDE per cable / MCB *) (no)	Ship set (QTY)	Ship set (start up effect) (W)
DN 65	100	75	36	16	1600
DN 80	100	75	36	14	1400
DN 150	190	120	19	20	3800
DN 200	250	190	14	10	2500
DN 300	250	190	14	16	4000
DN 350	500	380	7	4	2000
Total ship set				80	15300
*) 16A MCB 230 V	3680			No of cables	4

THE AERO SERIES

The AERO Series is our basic range of tank vent check valves produced as standard in carbon steel. Six different models, all with the same basic design and basic operational principle.

- ▶ All valves have the flat float principle, ensuring low leakage
- ▶ Sturdy design to withstand severe conditions
- ▶ Protection against corrosion, both on the in- and outside, hot dipped galvanized
- ▶ High performance, technical data available on request
- ▶ Optional materials: galvanized steel, aluminum, stainless Steel 316L higher Duplex steel qualities

The AERO Series is 2nd generation valve after our iconic TYPE AUTO developed in the 1970's. Type Auto obtained Type Approval certification by DNV in 1993 and is since that an internationally accepted standard in the maritime industry.

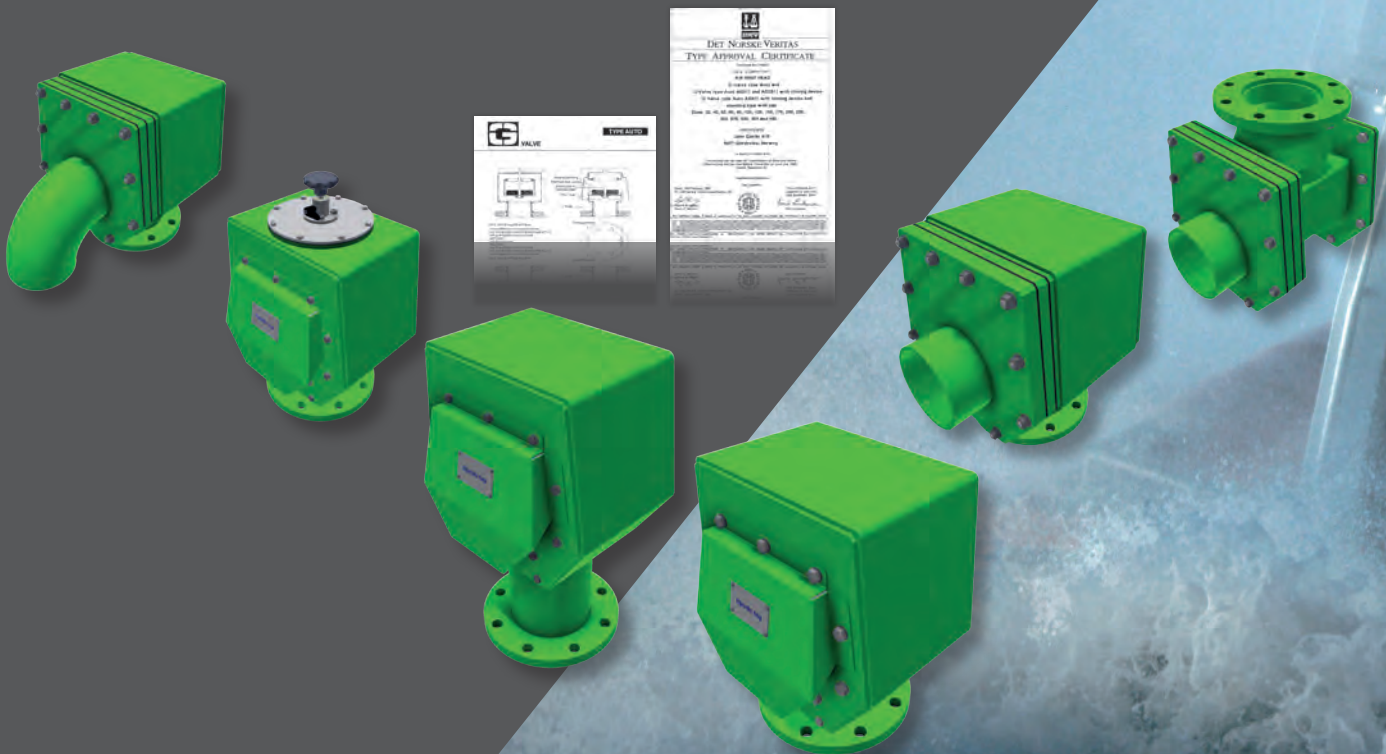

AERO 1.1

on deck

This Aero valve is the most commonly used air vent head for ships, ventilating all tanks on board for cargo, ballast water, wastewater, fresh water, lub. oil, fuel oil, etc. The Aero 1.1 version is made for on-deck mounting - outside. AERO valves are approved by all the most common classification societies.

Options:

- ▶ Flame/Bug/Rat screen
- ▶ Heating/Winterization
- ▶ Additional mud chamber preventing mud from entering the valve (see page 29)
- ▶ Painting
- ▶ Mounting alternatives: flanged, threaded or weldment
- ▶ Can be ordered in galvanized steel, aluminum, stainless steel or higher Duplex steel qualities

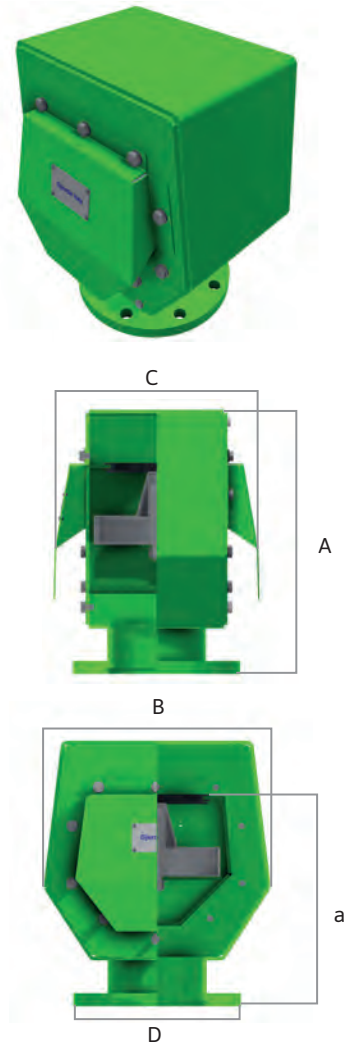

Performance, weight and size

Aero 1.1 Steel	DN – Inch														
	40- 1 1/2"	50 - 2"	65 - 2 1/2"	80 - 3"	100 - 4"	125 - 5"	150 - 6"	200 - 8"	250 - 10"	300 - 12"	350 - 14"	400 - 16"	450 - 18"	500 - 20"	600 - 24"
A (mm)	263	263	263	310	310	335	448	517	660	731	887	887	1100	1100	1100
B (mm)	216	216	216	273	273	305	385	475	590	685	885	885	1115	1115	1215
C (mm)	223	223	223	252	252	304	405	463	530	697	760	760	838	838	938
a (mm)	210	210	210	243	243	273	354	420	528	584	700	700	897	897	897
D	Flange connection acc. to any standard.														
Weight (kg)	13	14	15	20	21	26	41	63	97	121	175	205	384	395	416
Heating (Watt)	51	51	51	71	71	86	135	175	234	504	756	756	1185	1185	1565
Inlet air flow in m³/h¹⁾	100	130	190	380	480	885	1080	1925	3000	4325	6930	6790	11450	14845	16285
Inlet air flow in m³/h²⁾	105	150	190	450	480	885	1080	2035	3000	4325	5890	7240	10880	14845	16285

1) No screen 2) With screen

AERO 1.2

through superstructures

This air vent head is made for venting through superstructures. Commonly used in cases of longer distances to open deck, such as passenger vessels and accommodation areas.

Aero valves are approved by all the most common classification societies.

Options:

- ▶ Flame/Bug/Rat screen
- ▶ Heating /Winterization
- ▶ Additional mud chamber preventing mud from entering the valve (see page 29)
- ▶ Painting
- ▶ Mounting alternatives: flanged, threaded or weldment
- ▶ Can be ordered in galvanized steel, aluminum, stainless steel or higher Duplex steel qualities.

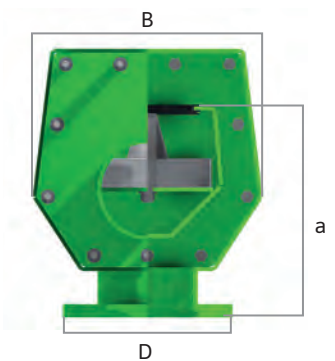
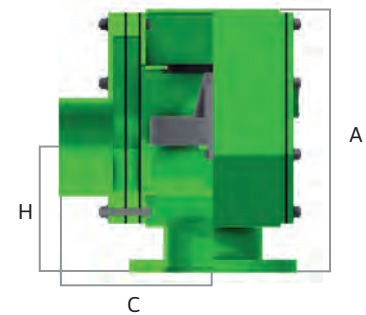

Performance, weight and size

Aero 1.2 Steel	DN - Inch											
	40 - 1 1/2"	50 - 2"	65 - 2 1/2"	80 - 3"	100 - 4"	125 - 5"	150 - 6"	200 - 8"	250 - 10"	300 - 12"	350 - 14"	400 - 16"
A (mm)	263	263	263	310	310	335	448	517	660	731	887	887
B (mm)	216	216	216	273	273	305	385	475	590	685	885	885
C (mm)	189	189	189	216	216	246	261	292	319	357	394	394
H (mm)	126	132	139	144	156	178	215	247	290	341	397	422
a (mm)	210	210	210	243	243	273	354	420	528	584	700	700
D	Flange connection acc. to any standard.											
Weight (kg)	26	26	27	40	41	53	84	122	191	248	392	398
Heating (Watt)	51	51	51	71	71	86	135	175	234	504	756	756
Inlet air flow in m³/h¹⁾	80	100	130	235	280	530	955	1810	2830	3565	4155	6785
Inlet air flow in m³/h²⁾	80	130	145	235	280	575	1020	2035	3000	3820	4155	5000

AERO 1.3

with closing device

This air vent is most commonly used for dry cargo tanks. Equipped with a manual closing device to avoid any leakage into the dry cargo. Aero 1.3 has determined flow characteristics and a robust lip seal gasket for optimal tightness.

Aero valves are approved by all the most common classification societies.

Options:

- ▶ Flame/Bug/Rat screen
- ▶ Heating /Winterization
- ▶ Additional mud chamber preventing mud from entering the valve (see page 29)
- ▶ Painting
- ▶ Mounting alternatives: flanged, threaded or weldment
- ▶ Can be ordered in galvanized steel, stainless steel or higher Duplex steel qualities

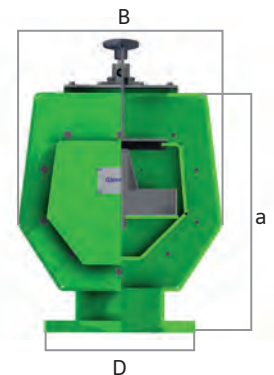
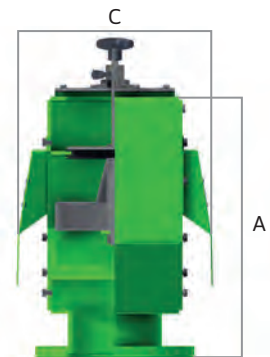

Performance, weight and size

Aero 1.3 Steel	DN - Inch															
	DN40 - 1 1/2"	DN50 - 2"	DN65 - 2 1/2"	DN80 - 3"	DN100 - 4"	DN125 - 5"	DN150 - 6"	DN200 - 8"	DN250 - 10"	DN300 - 12"	DN350 - 14"	DN400 - 16"	DN450 - 18"	DN500 - 20"	DN600 - 24"	
A (mm)	263	263	263	310	310	335	448	517	660	731	887	887	1100	1100	1100	
B (mm)	216	216	216	273	273	305	385	475	590	685	885	885	1115	1115	1215	
C (mm)	223	223	223	252	252	304	405	463	530	697	760	760	838	838	938	
a (mm)	210	210	210	243	243	273	354	420	528	584	700	700	897	897	897	
D	Flange connection acc. to any standard.															
Weight (kg)	19	20	21	27	29	34	49	72	112	-	-	-	-	-	-	
Heating (Watt)	51	51	51	71	71	86	135	175	234	504	756	756	1185	1185	1565	
Inlet air flow in m³/h¹⁾	100	130	190	380	480	885	1080	1925	3000	4325	6930	6785	11450	14840	16280	
Inlet air flow in m³/h²⁾	105	150	190	450	480	885	1080	2035	3000	4325	5890	7240	10880	14840	16280	

1) No screen 2) With screen

AERO 1.4

with sounding pipe

This air vent head is most commonly used for fuel tanks. It is equipped with a sounding pipe. Aero 1.4 has determined flow characteristics and good tightness performance.

Aero valves are approved by all the most common classification societies.

Options:

- ▶ Flame/Bug/Rat screen
- ▶ Heating/Winterization
- ▶ Additional mud chamber preventing mud from entering the valve (see page 29)
- ▶ Painting
- ▶ Mounting alternatives: flanged, threaded or weldment
- ▶ Can be ordered in galvanized steel, stainless steel or higher Duplex steel qualities

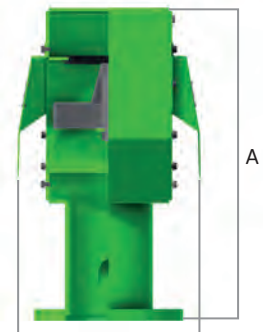

C

B

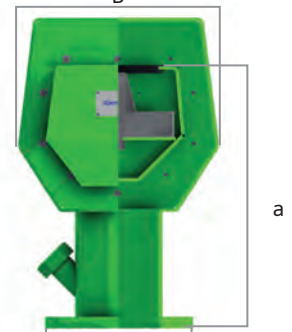

D

Performance, weight and size

Aero 1.4 Steel	DN - Inch											
	40 - 1 1/2"	50 - 2"	65 - 2 1/2"	80 - 3"	100 - 4"	125 - 5"	150 - 6"	200 - 8"	250 - 10"	300 - 12"	350 - 14"	400 - 16"
A (mm)	419	419	419	456	456	510	599	669	814	877	1056	1056
B (mm)	216	216	216	273	273	305	385	475	590	685	885	885
C (mm)	223	223	223	252	252	304	405	463	530	697	760	760
a (mm)	366	366	366	389	389	448	505	572	682	730	869	869
D	Flange connection acc. to any standard.											
Weight (kg)	14	15	16	22	22	29	45	68	103	129	185	215
Heating (Watt)	51	51	51	71	71	86	135	175	234	504	756	756
Inlet air flow in m³/h¹⁾	100	130	190	380	480	885	1080	1925	3000	4325	6930	6785
Inlet air flow in m³/h²⁾	105	150	190	450	480	885	1080	2035	3000	4325	5890	7240

1) No screen 2) With screen

AERO 1.5

with directed pipe

This vent check valve type, is made with a directed overflow. This is useful if venting is required from a specified location / tank / room.

Aero valves are approved by all the most common classification societies.

Options:

- ▶ Flame/Bug/Rat screen
- ▶ Heating/Winterization
- ▶ Additional mud chamber preventing mud from entering the valve (see page 29)
- ▶ Painting
- ▶ Mounting alternatives: flanged, threaded or weldment
- ▶ Can be ordered in galvanized steel, stainless steel or higher Duplex steel qualities.

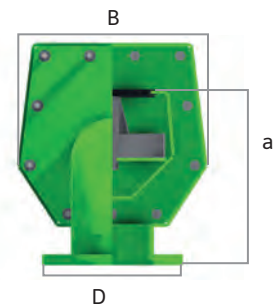
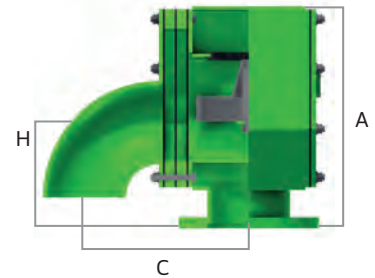

Performance, weight and size

Aero 1.5 Steel	DN - Inch											
	40 - 1 1/2"	50 - 2"	65 - 2 1/2"	80 - 3"	100 - 4"	125 - 5"	150 - 6"	200 - 8"	250 - 10"	300 - 12"	350 - 14"	400 - 16"
A (mm)	263	263	263	310	310	335	448	517	660	731	887	887
B (mm)	216	216	216	273	273	305	385	475	590	685	885	885
C (mm)	324	349	376	438	488	573	661	841	1008	1165	1347	1449
H (mm)	132	132	139	144	156	178	215	247	290	341	397	422
a (mm)	210	210	210	243	243	273	354	420	528	584	700	700
D	Flange connection acc. to any standard.											
Weight (kg)	26	26	27	40	41	53	84	122	191	248	392	398
Heating (Watt)	51	51	51	71	71	86	135	175	234	504	756	756
Inlet air flow in m³/h¹⁾	80	100	130	235	280	530	955	1810	2830	3565	4155	6785
Inlet air flow in m³/h²⁾	80	130	145	235	280	575	1020	2035	3000	3820	4155	5000

1) No screen 2) With screen

AERO 1.6

Inverted mounted

Vent check valve for venting through superstructures, made for inverted mounting with inlet at the top. All AERO valves are self-draining, which prevents leakage into the tank.

Aero valves are approved by all the most common classification societies.

Options:

- ▶ Flame/Bug/Rat screen
- ▶ Heating/Winterization
- ▶ Additional mud chamber preventing mud from entering the valve (see page 29)
- ▶ Painting
- ▶ Mounting alternatives: flanged, threaded or weldment
- ▶ Can be ordered in galvanized steel, stainless steel or higher Duplex steel qualities

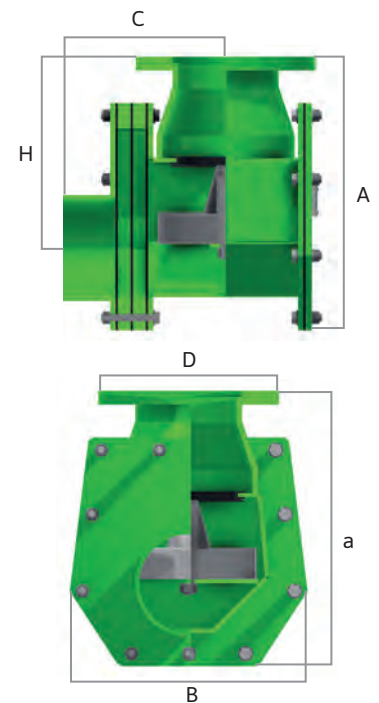

Performance, weight and size

Aero 1.6 Steel	DN - Inch											
	40 - 1 1/2"	50 - 2"	65 - 2 1/2"	80 - 3"	100 - 4"	125 - 5"	150 - 6"	200 - 8"	250 - 10"	300 - 12"	350 - 14"	400 - 16"
A (mm)	279	273	266	336	327	365	445	540	670	846	961	961
B (mm)	209	209	209	264	264	300	375	466	578	675	875	875
C (mm)	189	189	189	216	216	246	261	292	319	357	394	394
H (mm)	206	200	193	249	236	257	311	370	460	592	651	626
a (mm)	210	210	210	243	243	273	354	420	528	584	700	700
D	Flange connection acc. to any standard.											
Weight (kg)	24	24	25	36	38	47	76	111	182	221	221	221
Heating (Watt)	75	75	75	75	120	120	120	180	180	180	180	180
Inlet air flow in m³/h¹⁾	240	185	145	255	280	530	700	680	2830	4070	4850	7280
Inlet air flow in m³/h²⁾	320	320	155	255	280	530	700	1360	2830	4070	4850	7280

1) No screen 2) With screen

-STRAINERS

John Gjerde have more than 45 years of experience in special design and production of reliable and robust filters for seawater, fuel oil, mud, etc. We have in-house test facilities, and configuration knowledge for designing special filters, according to your specifications, and with swift delivery.

Our standard range:

- ▶ Several materials as carbon steel – black and galvanized, stainless steel, duplex, etc
- ▶ Designed for easy operation, easy maintenance and long lasting time
- ▶ From DN32 to DN1000

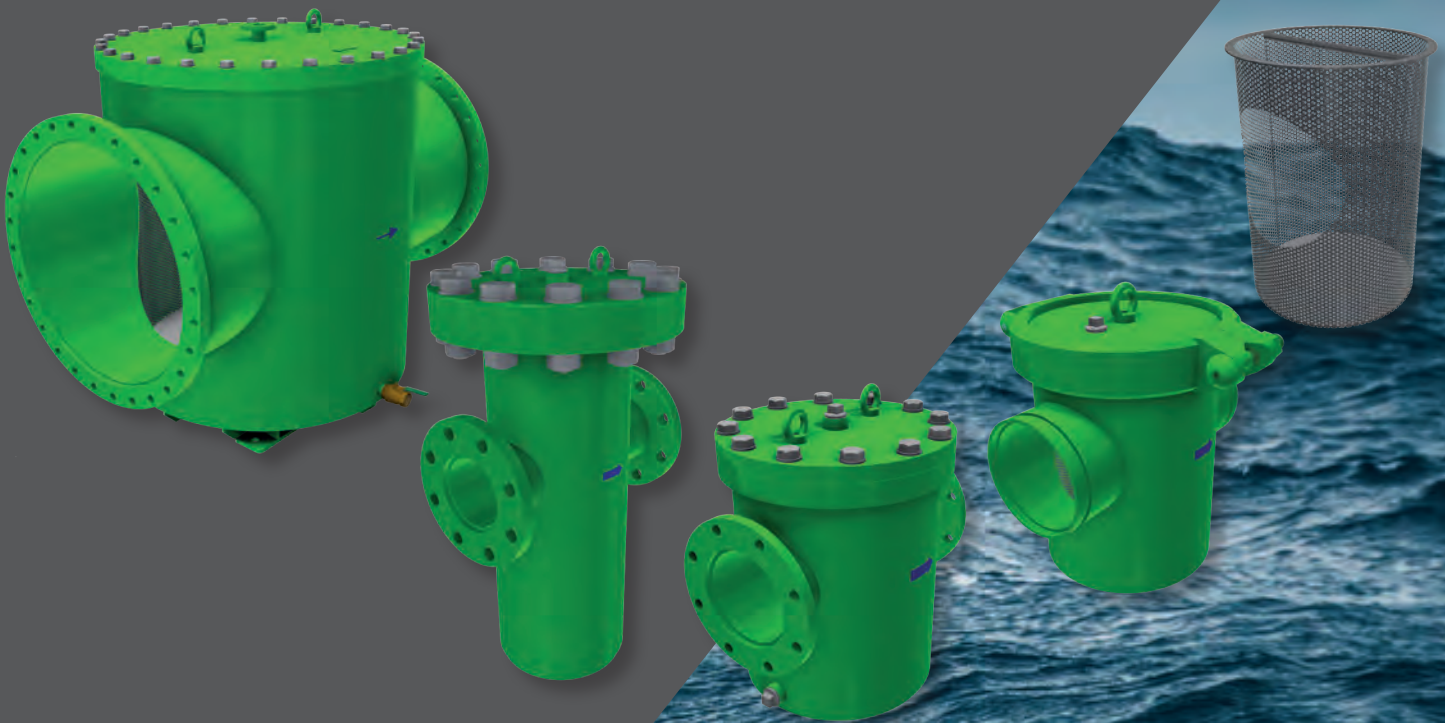

MUD STRAINER

Application area: mainly used for liquid mud filtration.

Function: separates coarse particles from mud, such as stone, etc.

The coarse fragments remain at the bottom of the filter.

Features to simplify supervision and maintenance, and to increase lifetime:

- ▶ Inlet connection at the top for installation of pressure gauge, or possibly flushing
- ▶ Outlet valve for drainage at the bottom
- ▶ Flange opening in the top of the filter for easy inspection
- ▶ Option: Zinc anode installed in the bottom of the filter
- ▶ Option: Custom specified in- and outlet solutions

Performance:

- ▶ Size: DN 100 to DN 250
- ▶ Operation pressure: up to 64 bar (High pressure)
- ▶ Standard filter perforations: D=10mm. (Can also supply other perforations)
- ▶ Materials: Carbon steel, SS316, Duplex, Super Duplex, others on request
- ▶ Surface treatment: painting or galvanization

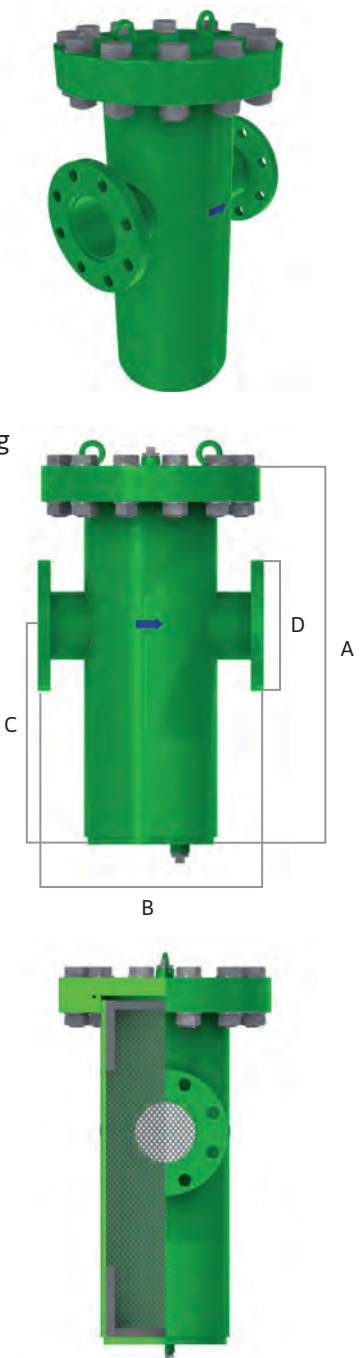

Weight and size

Plate strainer	DN - Inch				
	100 - 4"	125 - 5"	150 - 6"	200 - 8"	250 - 10"
A (mm)	871	871	871	871	871
B (mm)	463	463	463	463	463
a (mm)	450	450	450	450	450
D	Flange connection acc. to any standard.				
Weight (kg)	155	161	183	192	211

LIQUID STRAINER

Application area: mainly used for filtering sea water cooling systems. Can also be used for other types of liquids, such as fuel oil. Function: Separation of particles from liquids. The particles remain inside the bottom of the basket filter insert. Features to simplify supervision and maintenance, and to increase the lifetime of the strainer:



- ▶ Inlet connection at the top for installation of pressure gauge, or possibly flushing
- ▶ Outlet valve for drainage at the bottom
- ▶ Flange opening in the top of the filter for easy inspection
- ▶ The basket insert can easily be removed and cleaned
- ▶ Option: Zinc anode installed in the bottom of the filter
- ▶ Option: Custom specified in- and outlet solutions

Performance /size:

- ▶ Size: DN 320 to DN 1000
- ▶ Operation pressure: up to 64 bar (High pressure)
- ▶ Standard filter perforations: D=10mm
- ▶ Materials: Carbon steel, SS316, Duplex, Super Duplex, others on request
- ▶ Surface treatment: painting or galvanization

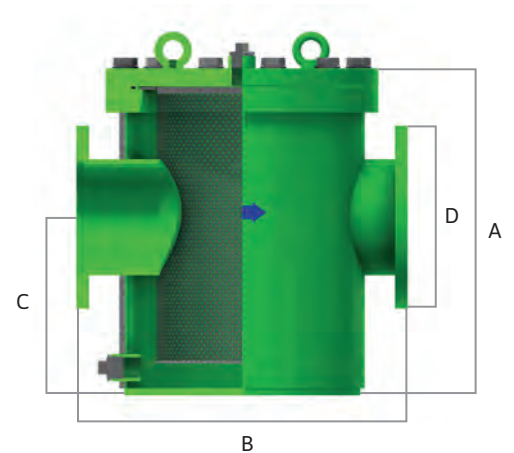

Weight and size

Basket strainer	DN - Inch														
	32 - 1 1/4"	40 - 1 1/2"	50 - 2"	65 - 2 2/5"	80 - 3"	100 - 4"	125 - 5"	150 - 6"	200 - 8"	250 - 10"	300 - 12"	350 - 14"	400 - 16"	450 - 18"	500 - 20"
A (mm)	250	260	260	260	310	352	450	474	593	609	609	790	790	1100	1100
B (mm)	200	290	290	290	310	350	400	480	600	600	600	740	740	1000	1080
C (mm)	91	110	110	110	130	195	275	258	340	340	340	400	400	610	610
D	Flange connection acc. to any standard.														
Weight (kg)	26	31	36	40	49	53	97	103	179	195	210	460	490	760	790

For bigger sizes, please contact us.

LIGHT LIQUID STRAINER

Application area: a smaller and lighter liquid strainer. Mainly used for filtering sea water cooling systems. Can also be used for other types of liquids, such as fuel oil. Function: separation of particles from liquids. The particles remain inside the bottom of the basket filter insert. Features to simplify supervision and maintenance, and to increase the lifetime of the strainer:

- ▶ Inlet connection at the top for installation of pressure gauge, or possibly flushing
- ▶ Outlet valve for drainage at the bottom
- ▶ Easy access through a grooved end coupling opening in the top of the filter for inspection
- ▶ The basket insert can easily be removed and cleaned
- ▶ Option: Zinc anode installed in the bottom of the filter
- ▶ Option: Custom specified in- and outlet solutions

Performance /size:

- ▶ Size: DN 32 to DN 250
- ▶ Operation pressure: up to 64 bar (High pressure)
- ▶ Standard filter perforations: Ø3, Ø5 or Ø8mm
- ▶ Materials: Carbon steel, SS316, Duplex, Super Duplex, others on request
- ▶ Surface treatment: painting or galvanization

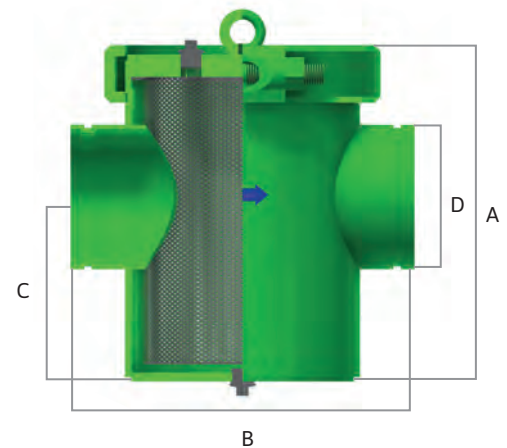

Weight and size

Basket strainer light	DN - Inch									
	32 - 1 1/4"	40 - 1 1/2"	50 - 2"	65 - 2 2/5"	80 - 3"	100 - 4"	125 - 5"	150 - 6"	200 - 8"	250 - 10"
A (mm)	159	180	213	233	283	313	339	392	443	480
B (mm)	160	180	200	250	280	300	350	400	500	540
C (mm)	75	90	105	125	155	185	185	215	241	256
D	Flange connection acc. to any standard.									
Weight (kg)	4	5	8	11	15	17	33	48	72	94

For bigger sizes, please contact us.

MUD BOX

Long lifetime ceramic reinforced coating

Mud box

Body carbon steel S235JR, produced acc. to DNV-GL OS 101

- ▶ Basket aisi 316, 100% isolated with rubber on connection surfaces to the body
- ▶ Straight and angle sizes from DN 32 to DN 1000

Coating

Internal paint in filters:

Ceramic reinforced coating

Brush-Roll-Spray Grade, Ceramic-Reinforced Erosion Resistant Coating

100% solids, ceramic reinforced thin film coating to protect filters against erosion, abrasion, and corrosion. The industrial coating is designed to:

- ▶ Protect against corrosion and erosion
- ▶ Provide improved material flow characteristics

External paint in filters:

NORSOK M-501 Surface preparation and protective coating, sys.1- Applicable for carbon steel with max operating temperature < 120°C The NORSOK standards are developed by the Norwegian petroleum industry to ensure adequate safety, value adding and cost effectiveness for petroleum industry developments and operations. Furthermore, NORSOK standards are as far as possible intended to replace oil company specifications and serve as references in the authorities' regulations.



CUSTOM MADE STRAINERS

☒-strainers can be manufactured according to customer requirements for special applications: e.g. limited space, abnormal pressures, need for extraordinary sizes or capacity. Please contact our Sales Department for more information about custom products. We deliver robust quality products acc. to specification, with short delivery time.

- ▶ Materials: Carbon steel, SS316, Duplex, Super Duplex, others on request
- ▶ Surface treatment: painting or galvanization
- ▶ Documentation: pressure drop calculation and testing on order request
- ▶ Configurations: acc. to customer specification, see examples beside

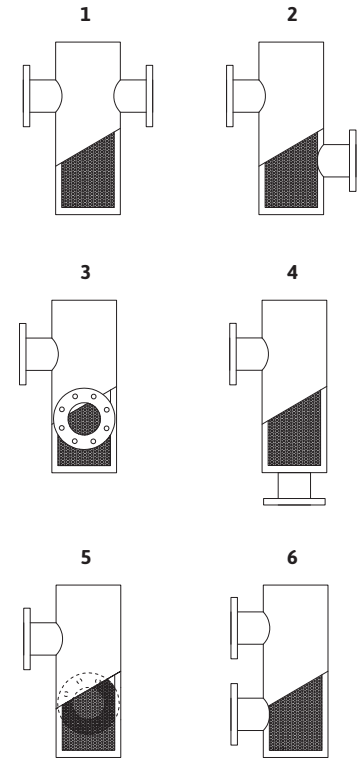

CUSTOM MADE BASKETS

The strainers are available in all kind of perforations and materials such as SS316, Duplex, Super Duplex, Monel, etc.

All customer-specific strainer baskets can be delivered with pressure drop documentation.



OTHER CUSTOM MADE SOLUTIONS

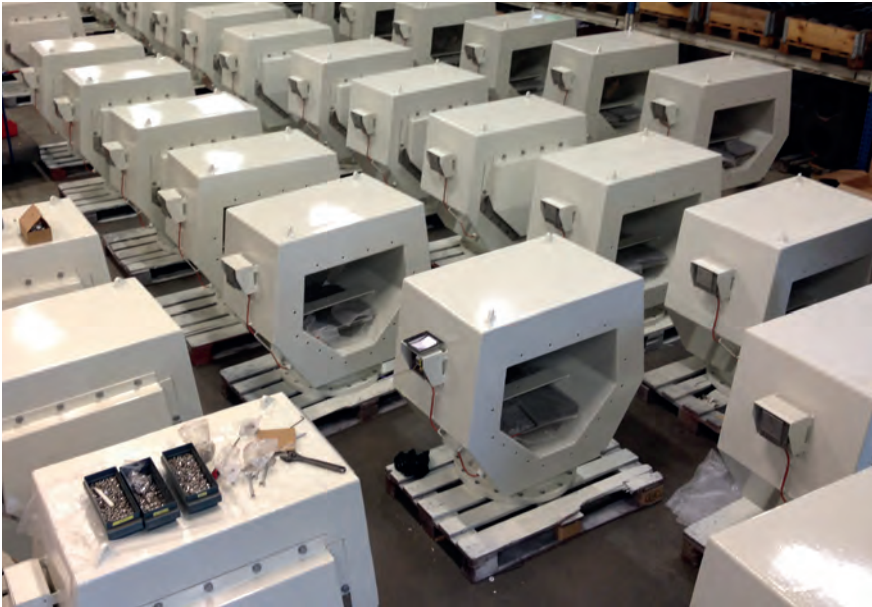

Do you have limited time or capacity in your project? Everything is possible – just ask us!

John Gjerde have more than 45 years of experience in the design of customized solutions on request. We contribute to the improvement of production efficiency for our customers.

- ▶ Tanks, valve boxes
- ▶ Fume Hoods, galley equipment, chutes
- ▶ Drain chutes
- ▶ Door linings
- ▶ Prefabrication of pipe-modules. We install Pipes, tanks, valves and fitting install on a foundation frame. The modules may be installed directly into the client project

John Gjerde has extensive knowledge of design and pipe configuration. Thanks to in-house production and own test facilities, the company can offer custom designs with documented performance, robust quality and short lead time.

Materials: Galvanized carbon steel, SS316, Duplex, Super Duplex, others on request.



OPTIONS

Three more models:

- ▶ Mud 1
- ▶ Mud Chamber
- ▶ Water Trap

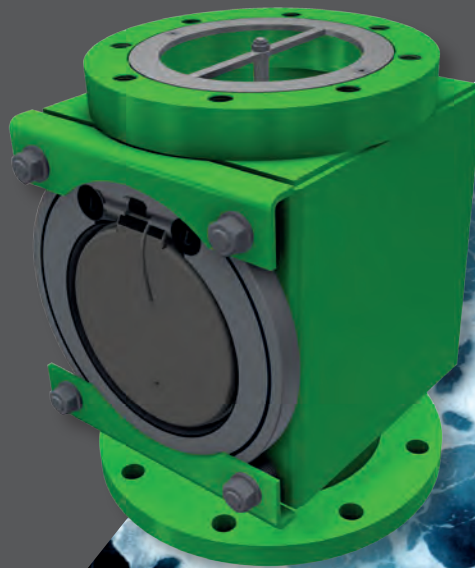

MUD 1

liquid mud valve

Integrated Mud Chamber for installation with an air vent head.
Commonly used for ventilating liquid mud tanks on offshore supply vessels.

If mud enters the Mud Chamber due to overpressure or overfilling, a one-way flap valve open to release pressure and mud. This is how the mud chamber prevents mud from entering the air vent head. Can be delivered with several types of air vent heads valves.

Mud 1 has documented flow characteristics.

Options:

- ▶ Heating/ Winterization
- ▶ Connection alternatives: Custom specified in and outlet solutions
- ▶ Materials: Carbon steel, SS316, Duplex, Super Duplex, others on request
- ▶ Surface treatment: painting or galvanization

Weight and size

Mud MUD 1	DN - Inch			
	125 - 5"	150 - 6"	200 - 8"	250 - 10"
A (mm)	820	840	860	890
B (mm)	305	340	432	482
C (mm)	335	345	435	585
a (mm)	760	760	760	760
D	Flange connection acc. to any standard.			
Weight (kg)	41	66	95	125

For bigger sizes, please contact us.

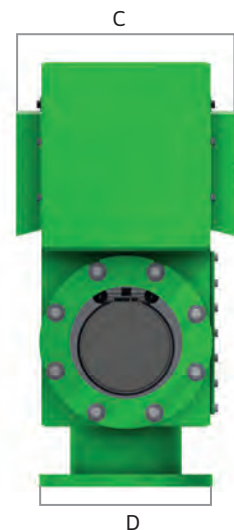
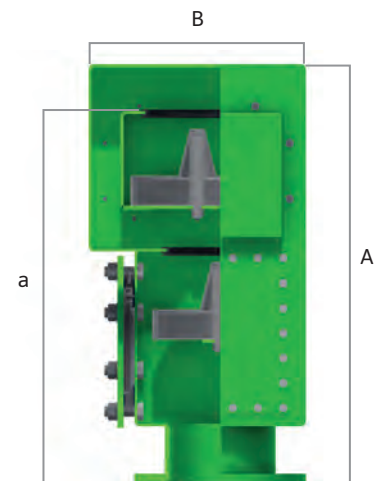

MUD CHAMBER

liquid mud chamber

Separate Mud Chamber for installation with an air vent head. Commonly used for ventilating liquid mud tanks on offshore supply vessels.

If mud enters the Mud Chamber due to overpressure or overfilling, a one-way flap valve opens to release pressure and mud. This is how the mud chamber prevents mud from entering the air vent head. Can be delivered with several types of air vent heads valves.

Options:

- ▶ Developed for retrofit and combination with HIDE and AERO tank vents.

Weight and size

Mud chamber	DN 125/150	DN 150/200	DN 200/250
A (mm)	335	400	510
B (mm)	318	346	430
a (mm)	195	217	280
D	Flange connection acc. to any standard.		
Weight (kg)	32	37	65

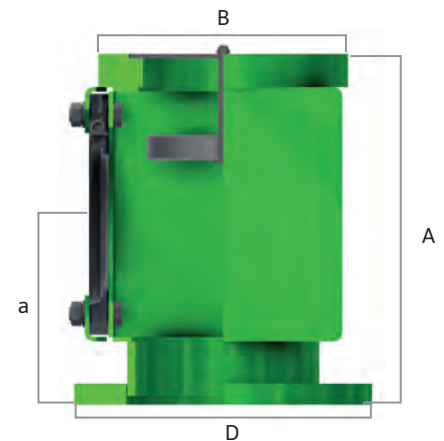

Example of venting configurations with AERO and HIDE valves on Mud Chamber.

WATER TRAP

liquid water trap

The John Gjerde water trap has been designed to prevent water leakage from stability tanks, preventing thus any stability loss of the ship.

In severe weather conditions, roll and pitch motions of the ship imply high level of filling in the stability tanks. The John Gjerde water trap will in such conditions prevent accidental discharge of water through the air pipe heads.

Water traps are designed to be placed under a -valve. The same configuration can be used for ballast water tanks or any tank where similar discharge situations can occur.

Another positive effect of the John Gjerde water trap is that it eliminates *suction blocking* at extremely high inlet air speeds (i.e. vacuuming of the float) when combined with our AERO and HIDE valves.

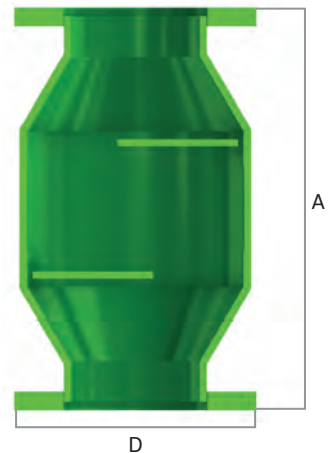

Weight and size

Water trap Steel	DN - Inch					
	100 - 4"	125 - 5"	150 - 6"	200 - 8"	250 - 10"	300 - 12"
A (mm)	424	424	476	576	900	1300
D	Flange connection acc. to any standard.					
Weight (kg)	13	16	19	27	75	100



Example of applications with AERO and HIDE valves on Water Trap.

INERT ADAPTER

for tanks that are inerted, to keep the inert gas contained

The challenge with inerting cofferdams and cargo tanks is to ensure proper tank ventilation in both inert and normal mode. With our new Inert Adapter this problem is solved.

The adapter can be used with any automatic closing device,

Options:

- ▶ Inerted tank: after closing the main ventilation head, pressure and vacuum relief is secured by the Inert Adapter.
- ▶ Normal mode: the main ventilation head is open and the valve functions normally

The opening settings for the pressure and vacuum relief valves is 200 mm water column (0.2 bar).

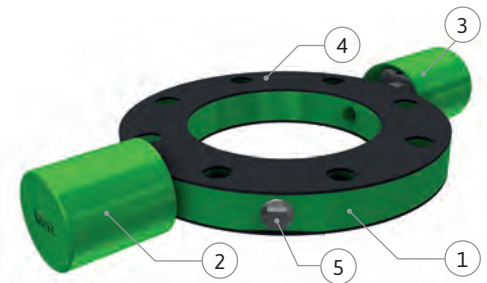
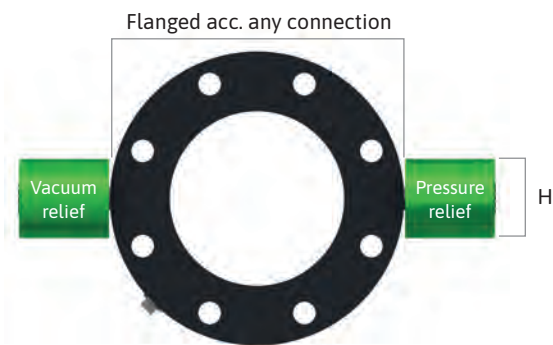

Performance, weight and size

Dim	L	H	B	Weight/kg
40	326	76	35	5.5
50	341	76	35	5.9
65	361	76	35	6.9
80	376	76	35	7.3
100	396	76	35	7.9
125	426	76	35	9.4
150	461	76	35	10.9
200	516	76	35	13.7
250	571	76	35	15.9
300	621	76	35	18.1

Pos	Qua	Description	Material
1	1	Flange	Aisi SS316
2	1	Vacuum relief valve	Aisi SS316
3	1	Pressure relief valve	Aisi SS316
4	2	Gasket	Rubber
5	1	Plug. (Option position for relief valve)	Aisi SS316





JOHN GJERDE™

GUARDING YOUR VALUES

Storehølvegen 10, N-6065 Ulsteinvik

+47 70 02 65 00

office@gjerde.com

www.gjerde.com